

OWNER'S MANUAL

Rigid Inflatable Boat

SERIE: "EAGLE"

MODEL: Eagle 6.7

complete sets: E6.7
E6.7H*

Design category (2013/53/EU): B or C
ISO6185-3: Type VIII

H* – boat tube is made of HYPALON (Du Pont registered trademark) coated fabrics.

CONTENTS:

DANGER LEVELS	5
INTRODUCTION	5
IDENTIFICATION PLATES	6
SAFETY REGULATIONS	7
BEAUFORT Wind Scale and Corresponding State of the Sea, After Few Hours of Wind, Away From the Coast.	8
BOAT DESIGN CATEGORIES	8
REMEMBER FIRE DANGER ALWAYS	9
TECHNICAL SPECIFICATIONS	10
COMPLETE SET	11
BOAT MAIN DIMENTIONS	12
BOAT DESIGN	13
RIGID HULL	14
REINFORCED BUOYANCY TUBE	15
CREW LIMIT	16
STERN MAST WITH ANCHOR LIGHT	18
STEERING CONSOLE	18
FUEL SYSTEM	20
SHOWER KIT	21
DRAIN SYSTEM	22
ANCHOR SYSTEM	24
HOW TO OPERATE ANCHOR SYSTEM	25
TOWING	27
MOORING	28
HOW TO INSTALL SUNDECK	29
REBOARDING MEANS	30
HOW TO INSTALL STORAGE BATTERY	31
WIRING DIAGRAM	32
INFLATION/DEFLATION BOAT TUBE	33
BOAT TRAILERING	34
MAINTENANCE	35
OPERATING REGULATIONS	36
WARNING SIGNS AND LABELS	42



For your safety and for the validity of the guarantee expert and authorized personnel must install the motor and inspect and check the systems. All onboard systems must be completed and inspected.

CHECK THAT THE CHECKS HAVE BEEN MADE AND THAT THE PLANTS HAVE BEEN COMPLETED BEFORE DELIVERY.

BRIG Ltd declines any responsibility for systems and accessories that have not been installed and checked by expert and authorized personnel.



The manual and all its enclosures should be stored carefully, and the manual should always be kept aboard. If the craft is resold, the manual and all its enclosures must be handed over to the new owner.

CE Certification and Main Features

The CE marking indicates that the inflatable boat meets the requirements of the Recreational Craft Directive 2013/53/EU

Certifying Body:

HPI Verification Services Ltd.

The Manor House
Howbery Park, Wallingford,
OX10 8BA, United Kingdom
EU Notified Body No. 1521
www.eucertification.com



Name of Manufacture:

BRIG Ltd.

Lozovskaya 88, Dergachy 62303
Shevchenko, 317, Kharkov 61033
UKRAINE
www.brigboats.com

DANGER LEVELS.

The manual contains warnings, identified as follows:

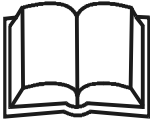
 <p>DANGER</p>	<p>A note like this indicates that there is serious risk that is likely to cause death or permanent serious injury, if appropriate precautions are not taken.</p>
 <p>WARNING</p>	<p>A note like this indicates the existence of risk that may cause death or injury, if appropriate precautions are not taken.</p>
 <p>ATTENTION</p>	<p>A note like this indicates reference to the application of safety or environmental protection practices, or draws attention to unsafe behaviour that might cause injury to persons or damage to the craft, its components or the environment.</p>

INTRODUCTION.

This manual was written to help you using your boat safely. It contains information of the boat, its equipments (supplied or installed), operation and maintenance.

 <p>DANGER</p>	<p>Before using your boat, read the MANUAL carefully and ensure that you have understood all the procedures it describes. Before taking command of your boat, be sure to have acquired experience and confidence in its operation.</p>
--	--

IDENTIFICATION PLATES.

Builder's Plate:

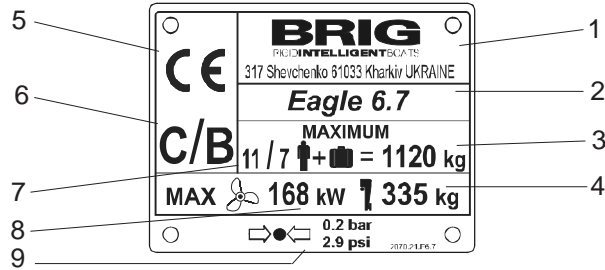

- 1 - Manufacturer's name and contact address of the manufacturer
- 2 - Model name
- 3 - Maximum load for the builder's plate (including mass of the persons and cargo onboard, but excluding mass of the max motor(s), the mass of the contents of fixed fuel and water tanks when full)
- 4 - Maximum mass of the outboard(s) including controls and batteries
- 5 - CE mark
- 6 - Design Categories C or B according to Directive 2013/53/EU
- 7 - Maximum recommended persons' capacity (75 kg each) for the Design Categories C or B
- 8 - Maximum outboard(s) power rating (in kW)
- 9 - Nominal pressure for each inflatable buoyancy chambers

Plate with identification number:



UA-QRK12345A000



It is fundamental for the plates to be aboard the boat, since they are only form of recognition and identification. Without them the boat does not comply with the legislation in effect. The plates must never be removed. Any tampering or removal not authorised by the manufacturer is the full responsibility of the owner.

SAFETY REGULATIONS.

This manual contains recommendations and basic rules of conduct for using the boat in complete safety. Although it is not possible to offer safety information for all potential situations, in general it is recommended that you:

	Regularly check which safety requirements are in force.
	Maintain the boat and the onboard plants in optimum condition.
	Have the boat inspected by the dealer where it was purchased or by an authorised machanic at least once every year for your own safety and for maintaining the guarantee.
	Always check weather and seagoing conditions before setting out. For safe navigation, compare the design category of your boat with the table above.
	The boat must be equipped with liferaft(s) to be stowed for the crew limit. If the liferaft is a rigid canister type, it shall be mounted in the cockpit, ready for use. If the liferaft is contained in a soft bag then it may be stowed in a compartment but shall be readily available for use.
	Max number of transportable persones is referred to an established weight of 75 kg per person (ISO 6185), so always make reference to total maximum transportable waight.
	The max weight of the installable motors indicates the maximum overall weight applicable on the stern board, including any emergency motors. NEVER exceed the stated value.

BEAUFORT Wind Scale and Corresponding State of the Sea, After Few Hours of Wind, Away From the Coast.

Force	Denomination	Knots	Km/h	m/sec	State of the sea and wave height in meters	
0	Calm	<1	<1	0-0.2	Calm	0
1	Light Air	1-3	1-5	0.3-1.5	Calm	0
2	Light Breeze	4-6	6-11	1.6-3.3	Almost calm	0.2
3	Gentle Breez	7-10	12-19	3.4-5.4	Almost calm	0.2
4	Moderate Breeze	11-16	20-28	5.5-7.9	Small waves	0.5
5	Strong Breeze	17-21	29-38	8.0-10.7	Large waves	1.25
6	Fresh Wind	22-27	39-49	10.8-13.8	Large waves	2.0
7	Strong Wind	28-33	50-61	13.9-17.1	Very large waves	2.5
8	Gale	34-40	62-74	17.2-20.7	Rough sea	4
9	Strong Gale	41-47	75-88	20.8-24.4	Very rough sea	6
10	Storm	48-55	89-102	24.5-28.4	Heavy	9
11	Violent Storm	56-63	103-117	28.5-32.6	Very heavy	14
12	Hurricane	64 and over	118 and over	32.7and over	Stormy	14 and over

Boat Design Categories (Directive 2013/53/EU):

Design category	Wind force (Beaufort scale)	Significant wave height*
"A" - "Ocean"	exceeding 8	exceeding 4
"B" - "Offshore"	up to, and including, 8	up to, and including, 4
"C" - "Inshore"	up to, and including, 6	up to, and including, 2
"D" - "Sheltered waters"	up to, and including, 4	up to, and including, 0.3

NOTE: *The significant wave height is the mean height of the highest one-third of the waves, which approximately corresponds to the wave height estimated by an experienced observer. Some waves will be double this height.

REMEMBER FIRE DANGER ALWAYS.

Fire may be caused by:

The manufacturer does not supply a fire extinguisher with a boat. A fire extinguisher must be installed on the boat by the owner. Responsibility for choosing the type of fire extinguishers, their number and capacity, as well as the installation location remains with the owner.

The owner should also know how to use a fire extinguishers and monitor its suitability. Consult a specialist to equip your boat with suitable fire extinguishers.



Never:

- obstruct access to safety controls, e.g. fuel shut-off valves, gas shut-off valves, isolation switches of the electrical system or fire ports;
- deliberately or inadvertently block ventilation for compartments or spaces, particularly those containing petrol engines, fixed petrol tanks and batteries;
- obstruct access to portable fire extinguishers or fire ports;
- leave the craft unattended when cooking and/or heating appliances are in use unless the appliance is designed to operate unattended;
- modify any of the craft's systems unless competent to do so;
- fill any fuel tank or replace gas bottles when engines are running or open flame appliances or radiant heat devices are in use;
- smoke while handling fuel or gas;
- store petrol containers or equipment containing petrol in any area not designated for the specific storage of petrol.



However, if a fire does occur aboard, stop motor, disconnect the batteries immediately, check to see if it is an electrical component or any case a small-scale fire that does not involve flammable liquids, in which case use a suitable fire extinguisher to try and put the fire out completely.



Extinguisher or any other fire-fighting equipment must not be kept in compartments with key lock, but in easily accessible and clearly indicated locations.

Extinguisher or any other fire-fighting equipment should be checked periodically and replaced with the same or superior types **if expired or inefficient.**

TECHNICAL SPECIFICATIONS.

The basic parameters and dimensions of the Eagle 6.7 comply with the data specified in the following table. All dimension measurements indicated have a tolerance of +/- 2.5%, weight measurements indicated have a tolerance of +/- 5%.

Parameter	Eagle 6.7
Length (without engine)	6.70m
Beam	2.55m
Height	1.92m
Inflatable tube diameter, max.	0.55m
Cockpit dimensions:	
- length	4.70m
- width	1.45m
Deadrise angle on transom	16°
Deadrise angle in middle section	21°
Transom height	630mm (25")
Number of independent air-tight chambers	5
Nominal pressure	0.2bar (2.9psi)
Crew limit (persons)	7/11 (B/C Design Category)
Recommended engine power	175-200 HP
Maximum engine power	168kW / 225 HP
Maximum engine weight (including controls and batteries)	335kg
Engine shaft length	XL / 25"
Weight of empty boat (with steering console, with arc, with seats, without engine)	780kg
Weight of boat with equipments from manufacturer (without engine)	810kg
Carring capacity of the boat	1660kg
Displacement In Light Craft Condition (LCC)	1160kg
Maximum total load ML (total weight of the fuel, weight of the people and cargo onboard)	1310kg
Maximum load for the builder's plate (includes passengers and cargo onboard, but excludes mass of the max engine, mass of the contents of fixed fuel, water tanks when full)	1120kg
Loaded displacement mass (LDC)	2470kg

COMPLETE SET Eagle 6.7

In the table below is shown the maximum possible complete set, which may differ from your boat.

Rigid Inflatable boat	+	Shower kit :	
Foot pump	+	Water tank (45 litres)	+
Paddle	+	Shower handset	+
Set of spare parts and repair kit	+	Shower pump	+
Bag	+	Removable sundeck	+
Owner's manual	+	Front locker removable cushion	+
Valve cap pressure gauge	+	Rear platforms	+
Steering console	+	Foldable stainless steel ladder	+
Steering console equipments:		Overall cover	+
-Mechanical steering system	+	Cover for steering console and seat	+
-Hydraulic steering system	option	Collapsible sun-top	+
-Steering wheel	+	Battery container	+
-Fuel level clock	+	SeaDek set	+
-Electrical switches with fuses	+	Anchor system with anchor, electrical windlass, anchor chain/rope	option
-Socket 12V with fuse	+		
-Speedometer	+		
-Tachometer	+		
-Compass	+		
-Electric horn	+		
Driver seat	+		
Stern mast with anchor light	+		
Stern soft seat with backrest	+		
Front step-plate with navigation lights	+		
Fuel system with fuel tank 191 litres	+		
Drain system with automatic bilge pump	+		

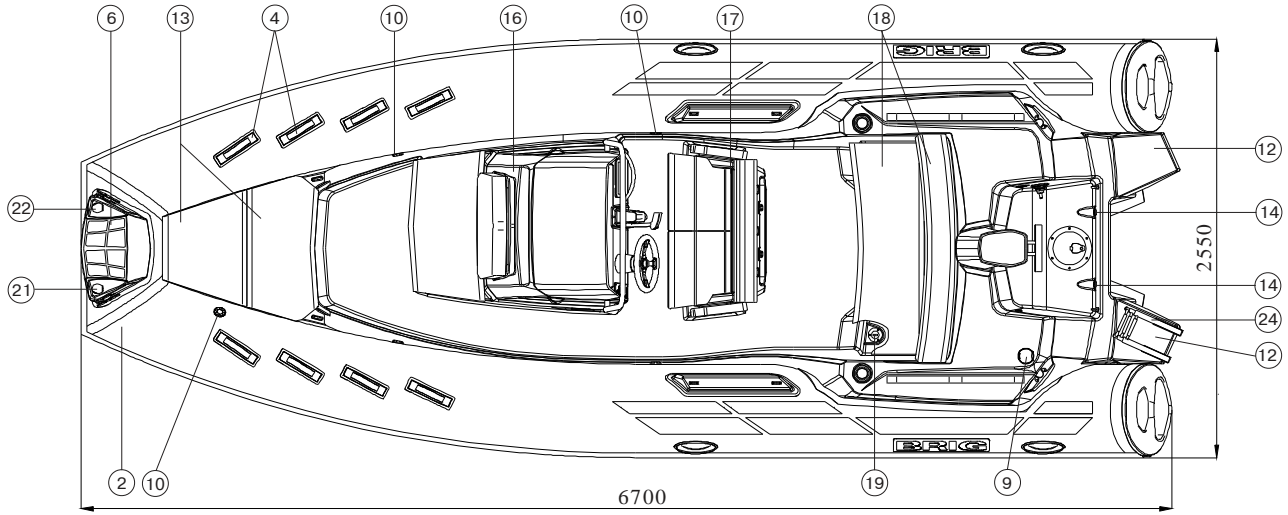
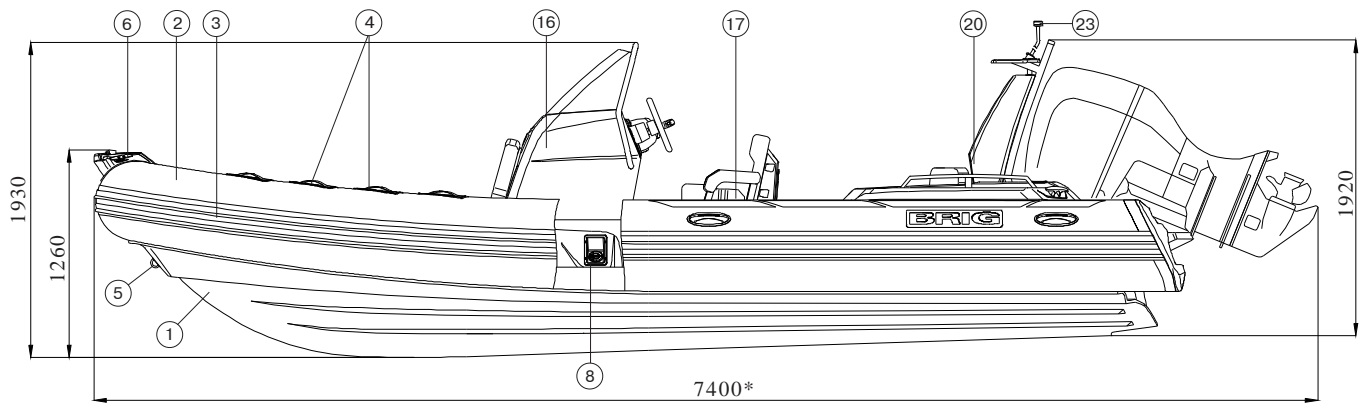

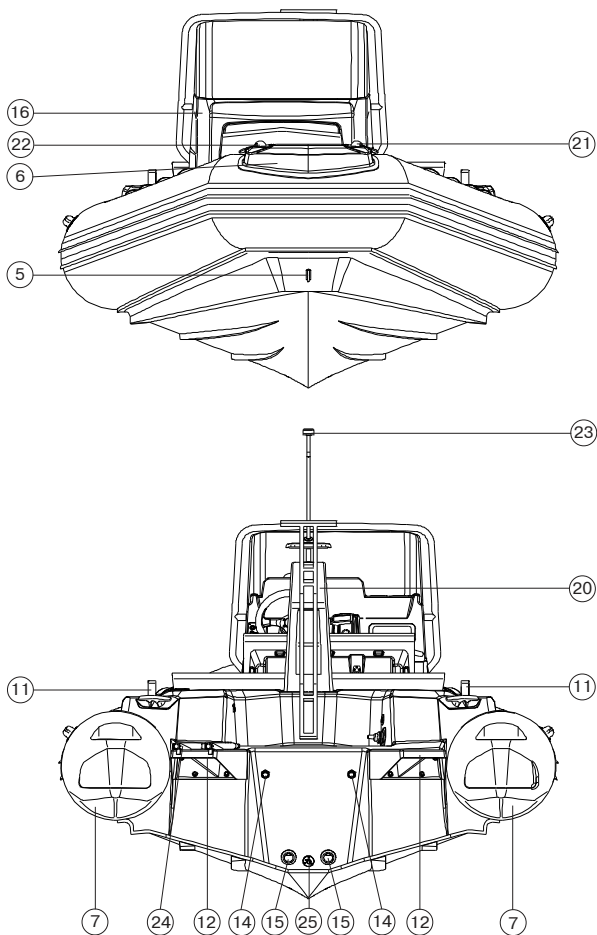

BOAT DESIGN.

The boat series "EAGLE" E6.7, E6.7H consists of the next main components:

- polyester hull (1);
- reinforced buoyancy tube (2);
- polyester steering console (16);
- combined pilot seat/bolster (17);
- stern mast (20) with anchor light (23).

DESCRIPTION:

- 1 — Rigid hull.
- 2 — Reinforced buoyancy tube.
- 3 — Doubled rubbing strake.
- 4 — Safety handle.
- 5 — Towing bow eye (hull).
- 6 — Bow step-plate with navigation lights.
- 7 — Fiberglass tube end (2 pcs.)
- 8 — Fuel fill.
- 9 — Box with cap for shower handset.
- 10 — Air fill valve (5 pcs.).
- 11 — Stern handhold.
- 12 — Stern platforms.
- 13 — Front locker removable cushion (2pcs.).
- 14 — Drain outlet from the motor recess (2 pcs.).
- 15 — Cockpit drain system socket (2 pcs.).
- 16 — Steering console.
- 17 — Combined pilot seat/bolster.
- 18 — Stern-part seat with soft back.
- 19 — Water fill.
- 20 — Stern mast.
- 21 — Port running light (red).
- 22 — Starboard running light (green).
- 23 — Anchor light (white).
- 24 — Foldable stainless steel ladder.
- 25 — Drain plug.

D1

RIGID HULL.

The boat hull has "deep-V" shaped bottom with four longitudinal steps. The upper deck surface has a special moulded antiskid coating. There are five specified sections (Fig. D2):

- bow anchor locker (1) is intended for arrangement of anchor and anchor chain/rope;
- bow locker (2) is intended for baggage arrangement;
- locker under the seat of steering console base part (3) is intended for baggage arrangement;
- deck compartment (4) is intended for arrangement of fuel tank;
- stern locker (7).

In addition there is polyester underpan installed into the steering console base part (6), which separate steering console from deck compartment. The bow locker and stern locker have a direct access by hinge out the access doors (respectively 15 and 17 positions). There is an inspection hatch located on the deck (16) for survey of the fuel tank, pipe lines and electric contacts.

Onto the bow locker there are removable soft cushions (13, Fig. D1). Onto the stern locker there are soft seat with soft back (18, Fig. D1).

The boat hull is arranged with the following components:

- bow towing eye (5);
- two stern cleats (19, Fig. D2e);
- fuel tank (8);
- water tank (9);
- fuel fill (10, Fig. D2a);
- water fill (12, Fig. D2b, D2d);
- box with cap for shower handset (18, Fig. D2e);
- foldable stainless steel ladder (20);
- lifter of stern locker seat;
- cockpit drain systems sockets (11, Fig. D2b, D2c);
- battery disconnecter (13, Fig. D2b);
- drain automatic bilge pump (14, Fig. D2c);

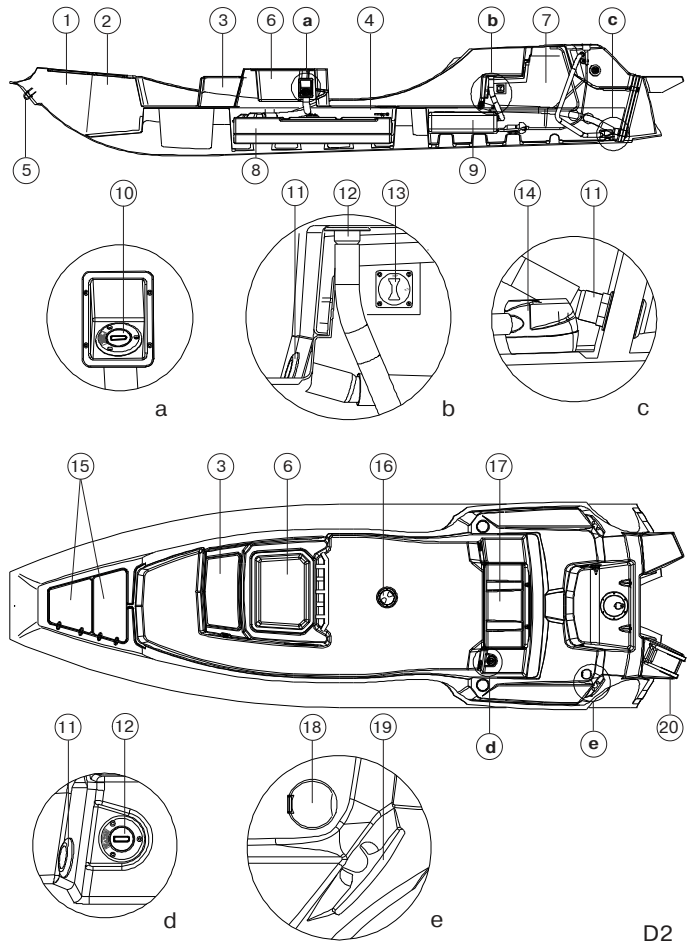

D2

The bow part of the boat may be simply converted into the sundeck by means of sundeck floor boards and sundeck soft cushions.

REINFORCED BUOYANCY TUBE.

The boat buoyancy tube has U-shaped form. The tube is separated by means of inner elastic partitions into five chambers of a similar volume, each being provided with an air fill valve.

The air fill valve is intended for:

- filling the compartment with air from a standard pump or filling system and maintaining pressure in the tube for prolonged time,
- adjustable drop of pressure in compartment.

The air fill valve is designed as a tab-type non-return valve and consists of the following components (Fig. D3):

- housing (1);
- cup (2) with strap (3);
- washer with gasket (4);
- nut (5);
- spindle (6) with spring (7) and cup diaphragm (8).

Also there are the following elements fitted on the tube (Fig. D1):

- doubled rubbing strake (3, Fig.D1);
- safety handles (4, Fig.D1);
- bow step-plate with navigation lights. (6, Fig.D1);
- tube polyester ends (7, Fig.D1) with two antiskid steps each.

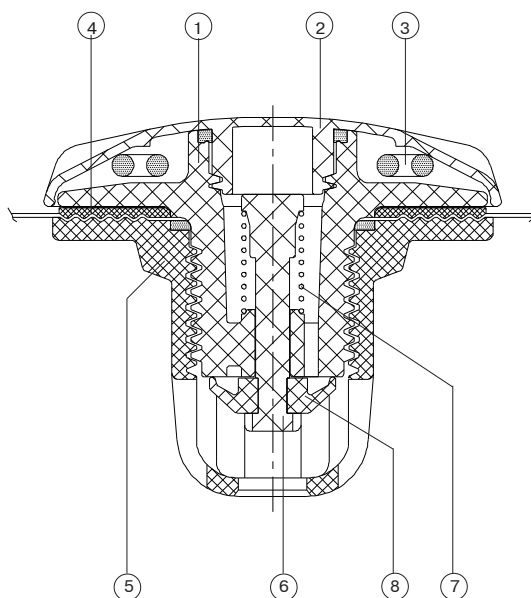

D3

CREW LIMIT.

On the picture (Fig.D3.1) you can see the recommended location of the crew in the boat.

Note the differences in crew accommodation for Design Category C and B.

All persons should always use the handholds to avoid falling overboard. On Fig.D3.1 you can see the location of the handholds for each crew member. Any part of the boat can be a handholds that can be grabbed by hand to reduce the risk of falling overboard. Example handholds: handle, shroud, seat edge, cleats, steering wheel.

If your boat is equipped with a SunTop (Fig.D3.1), persons "G" and "I" can use it as a handhold. The SunTop should be folded and fixed while the boat is moving. If your boat is not equipped with a SunTop, persons "G" and "I" should use rear handrails as a handhold. Person "H" should use seat edge or rear lower handle as a handhold.

Folding table (Fig.D3.1) can not be used as a handhold. The table should be folded while the boat is moving.

For the safe placement of persons "A","B","C","D" SunDeck (Fig.3.1) must be folded while the boat is in moving.

Persons "K" and "L" can be placed on the buoyancy tube in designated seating area (only for Design Caterory C). Persons on the tube should always use two handholds at the same time so as not to fall overboard.

If your boat is used for Design Category B, the crew accommodation spaces indicated in the picture (Fig.3.1) as "A", "B", "K", "L" cannot be used while the boat is moving.

 WARNING	Periodically check the handholds. There should be no damage on the handholds and their fixation.
---	--

 WARNING	Always check the correct and safe accommodation of all persons in the boat.
---	---

 WARNING	Reduce speed when persons are sitting on the buoyancy tube.
---	---

 WARNING	There are differences in crew accommodation for Design Category C and B.
---	--

Design Category C
Crew limit - 11 max.

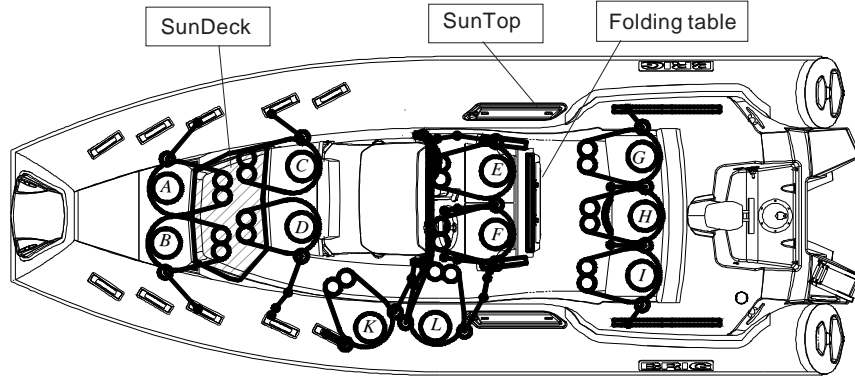

Design Category B
Crew limit - 7 max.

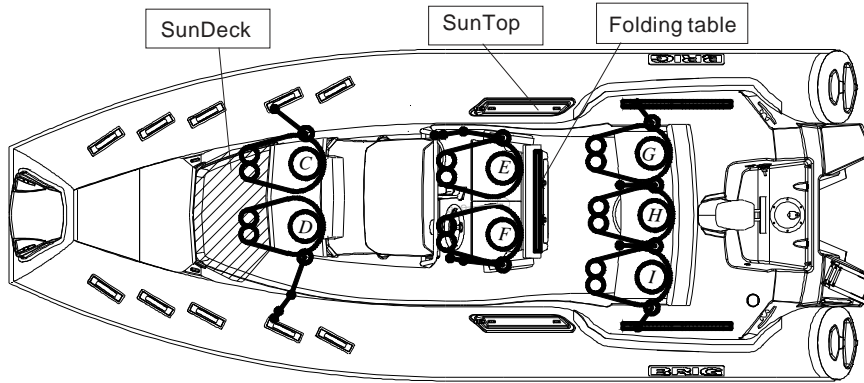

D3.1

STERN MAST WITH ANCHOR LIGHT.

Stern mast (20, Fig.D1) is located in the stern part of the boat.

Mast equipment:

- anchor light (white, 23).

STEERING CONSOLE.

Steering console is located in the central part of the boat. The console consists of the following components (Fig. D4):

- console body (1) is installed on the built-in the boat deck console base
- windscreen (2);
- stainless steel railing (3);
- front soft seat ;
- soft seat-back (4);
- hatch (5).
- console recess (6);
- fuel fill (10, Fig. D2a);
- stainless steel handrail (7);
- electric horn (8);
- compass (9);
- steering wheel (10);
- switch panel (11);
- cup holders (12).

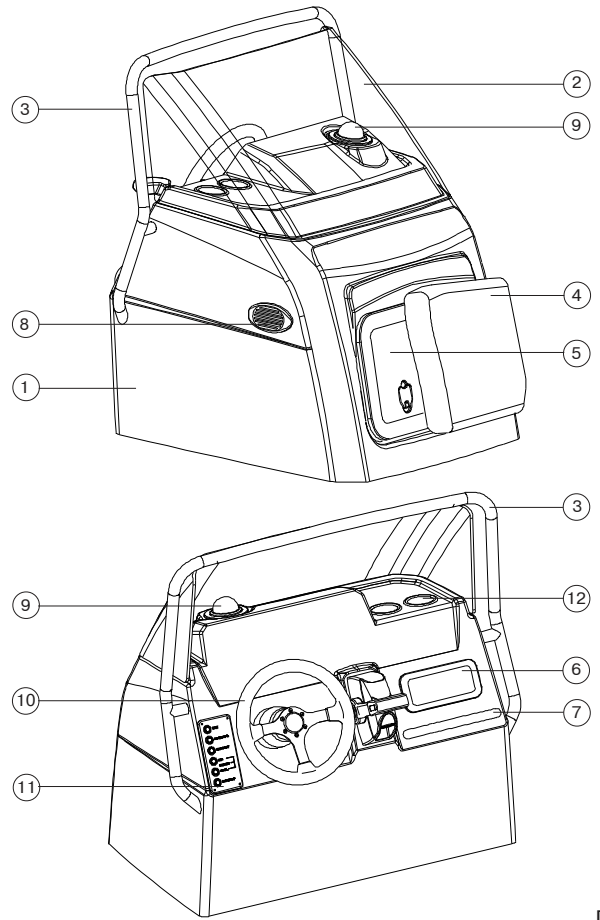

D4

Console equipment (Fig. D5):

- steering system;
- steering cable;
- steering wheel (5);
- compass (1);
- fuel level clock (2);
- speedometer (3);
- tachometer (4);
- sockets 12V (6);
- fuse holding box with warning lights(Fig. D5)
(inside of the steering console);
- switches:— horn switch (7);
 - running lights and meter lamp switch (8);
 - anchor light switch (9);
 - hull drain pump switch "Manual" (10);
 - shower pump switch (11);
 - anchor "Up"/"Down" switch (12);

Access to the fuse box - through the hatch (7, Fig. D4)

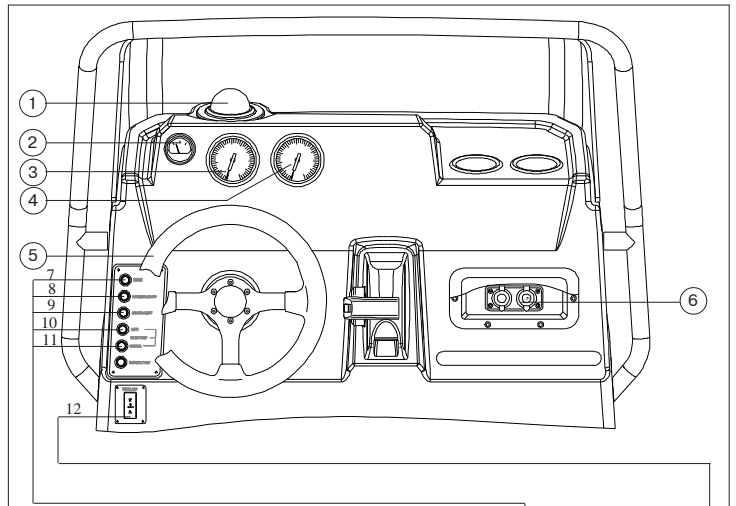

WARNING

Always check the fuse. Burning red LED display on the fuse box warns of faulty fuse

WARNING

Always keep a spare set the fuse in an easily-accessible location.

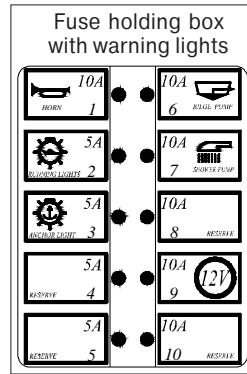

Switch panel	
<i>horn switch</i>	7
<i>running lights and meter lamp switch</i>	8
<i>anchor light switch</i>	9
<i>hull drain pump switch "Manual"</i>	10
<i>shower pump switch</i>	11

anchor 12
"Up"/"Down"
switch

D5



FUEL SYSTEM.

Fuel system consists of the following components (Fig. D6):

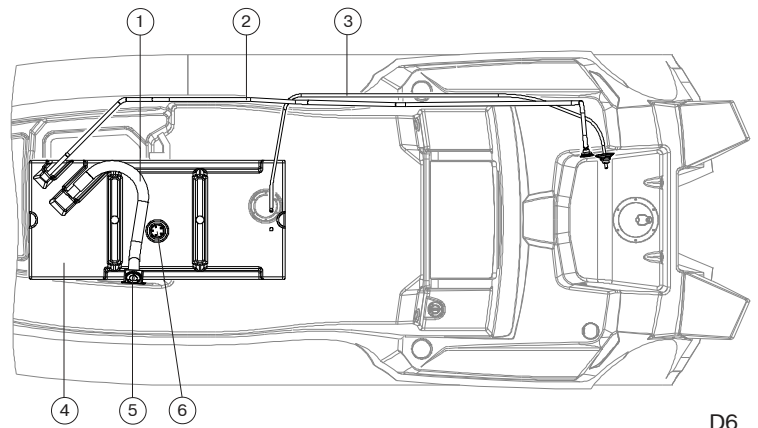
- built-in fuel tank 191 L (4);
- external fuel fill (5);
- fuel line (from fuel fill to fuel tank) (1);
- fuel line (from fuel tank to engine) (3);
- electric fuel gauge (6);
- fuel drain line (2).



D6

 DANGER	Pre-filter and fuel valve must be installed by authorized representative specialists only.
	Do not modify fuel system. Any modification, repair and planned maintenance of the fuel system may be made by authorized representative specialists only.
	Check that there are no leaks in the fuel systems
 WARNING	Do not smoke when refueling. Stop the engine and switch off any electric equipments before refueling.

SHOWER KIT.

Shower kit includes the next components (Fig. D7):

- water tank (1);
- water fill (2);
- water drain line (3);
- water line (from water fill to tank) (4);
- water line (from water tank to shower pump) (5);
- water line (shower hose) (6);
- shower pump (7);
- box for shower handset (8);
- shower handset with push button control and shower hose (9).

How to use a shower:

- Activate the shower pump with the "Shower pump" switch on the console switch panel.
- Wait a few seconds.
- Take the shower handset and press the button on it.
- Put the shower handset back in the container after use.

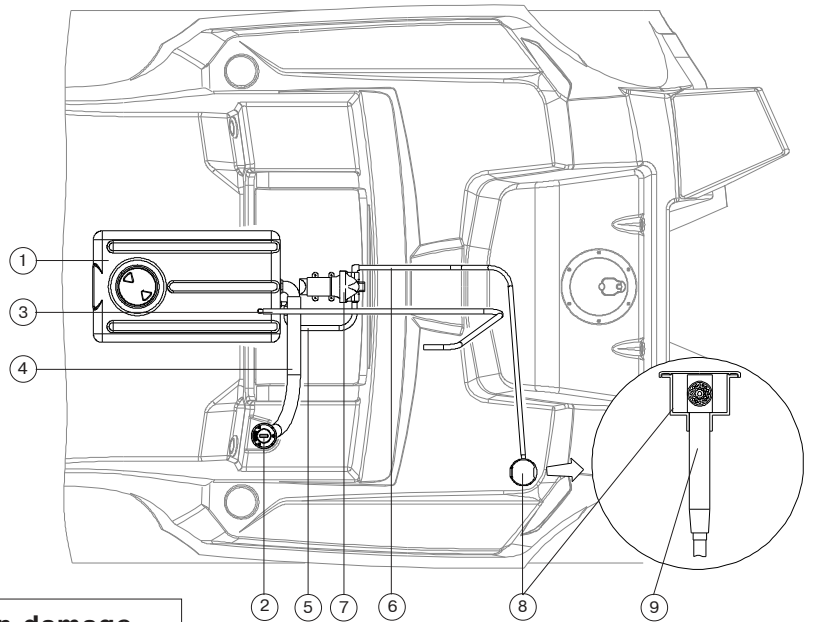

 WARNING	<p>Water on freezing can damage the shower system. Water from the tank and hoses must be removed if there is a risk of freezing.</p>
---	---

D7

 WARNING	<p>It is dangerous to pretend to be an expert. This may cause damages. Refer to expert and authorized specialists for all types of maintenance and repair.</p>
---	--

DRAIN SYSTEM.

Drain system, (Fig. D8), consists of the three independent systems:

- cockpit drain system;
- hull drain system;
- motor recess drainage.

COCKPIT DRAIN SYSTEM:

- two cockpit drain sockets (1);
- two stern drain sockets with flexible diaphragms (2);
- two drain hoses (3);

HULL DRAIN SYSTEM:

- automatic bilge pump (4);
- battery disconnecter panel (7);
- drain hose (5);
- bilge pump drain outlet into the motor recess (6);
- drain plug (8) **MUST BE TIGHTLY CLOSED WHEN BOAT ON WATER;**

MOTOR RECESS DRAINAGE:

- two drain outlets from the motor recess (9);

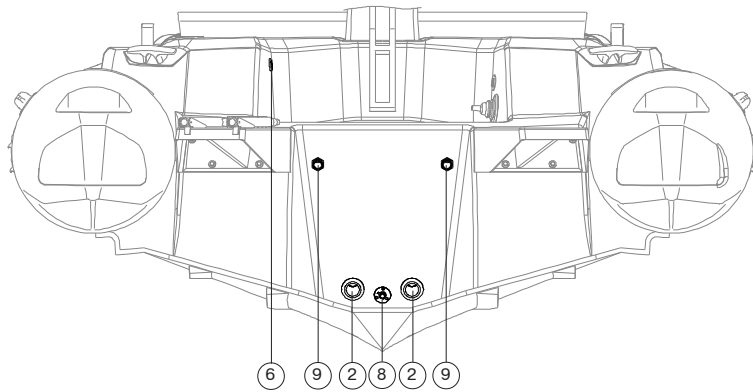
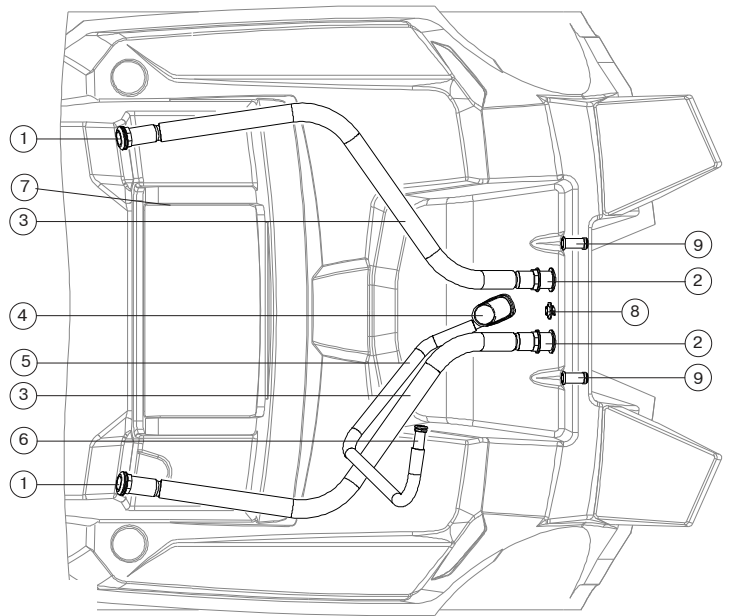

Battery disconnecter panel (7)

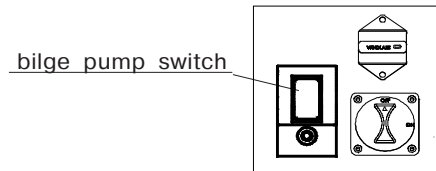



D8

How to operate with bilge pump:

1. Open the rear hatch
2. On the battery disconnecter panel ((7) fig.D8) to the left of you, locate the bilge pump switch with fuse.
3. Select the desired operating "Auto" mode only.
4. The bilge pump will be in the active position, even if all the battery disconnectors on this panel are turned off.
5. On the switch panel on the steering console to activate the bilge pump, you can use the "Manual" mode only.

 <p>WARNING</p>	<p>Make sure the pump is working. To do this, activate the pump by selecting the "Manual" mode. You should hear the sound of a running pump.</p> <p>Always keep the pump active in the "Auto" mode if the boat is on the water.</p> <p>ATTENTION. The pump is connected to the battery. A working pump can discharge the battery. Have on board other means for draining a boat (for example a hand pump)</p>
---	--

 <p>WARNING</p>	<p>Always the cockpit drain sockets must be open during navigation. Do not obstruct cockpit drain sockets at any time. Do not dispose bulky objects in front of the cockpit drain sockets.</p>
---	--

 <p>WARNING</p>	<p>Do not modify drain systems. Before navigation check the drain valves.</p>
---	---

 <p>WARNING</p>	<p>It is dangerous to pretend to be an expert. This may cause damages. Refer to expert and authorized specialists for all types of maintenance and repair.</p>
---	--

 <p>WARNING</p>	<p>Never locate heavy objects on the drain hoses. It will be cause of bucking, distortions and damages.</p>
---	---

ANCHOR SYSTEM (OPTION).

Anchor system is located inside the bow anchor locker (Fig. D9).

Anchor system includes the next components:

- stemhead roller (1);
- electrical anchor windlass (2);
- clutch nut (3)
- anchor (4) with shackle (4a);
- anchor chain / rope (38m length) (5);
- safety pin (6);
- drain opening (7);
- windlass circuit breaker (8) (installed on the battery disconnecter panel);
- anchor windlass "up" and "down" additional switch (on the steering console, fig.D5);
- windlass control box (installed in the interior space of the steering console).

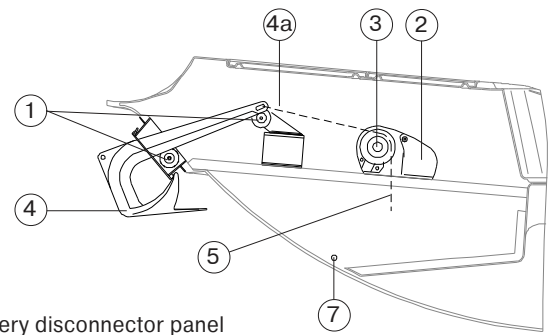

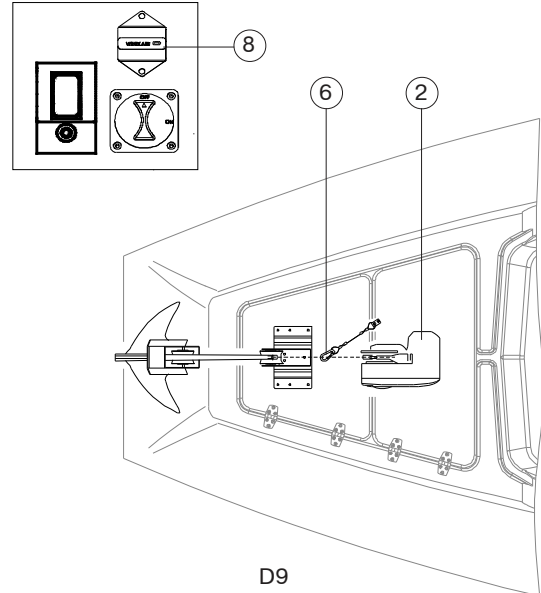

Battery disconnecter panel



D9

BRIG

 WARNING	<p>Strong point of anchor system is designed for a maximum horizontal load of 19.3kN. The breaking strength of rope shall in general not exceed 80 % of the breaking strength of the respective strong point.</p>
---	---

 ATTENTION	<p>Before beginning to operate with anchor system, carefully study the owner's manual for electric windlass.</p>
---	--

 WARNING	<p>Periodically check that the special anchor shackle (4a fig.D9) are tightened correctly.</p>
--	--

HOW TO OPERATE WITH ANCHOR SYSTEM.

Before beginning to operate with anchor system, carefully study the owner's manual for electric windlass. Please, respect all requests and follow all instructions stated in above indicated manual.

If you need to drop/cast the anchor by electric motor:

1. Disconnect main battery disconnecter.
2. Open the bow anchor hatch. By means of handle (supplied) close the clutch nut (3, fig.D9).
3. Disengage safety pin (6, fig.D9) from chain.
4. Windlass circuit breaker (8, fig.D9) and battery disconnectors must be switch on.
5. By means of anchor windlass "up" and "down" switch drop/cast the anchor.
6. Switch off the main battery disconnecter. Close the bow anchor hatch.

If you need to stow the anchor by electric motor:

1. Disconnect main battery disconnecter.
2. Open the bow anchor hatch. By means of handle close the clutch nut (3, fig.D9).
3. Check that the safety pin (6, fig.D9) is detached from chain.
4. Windlass circuit breaker and battery disconnectors must be switch on.
5. By means of anchor windlass "up" and "down" switch begin to stow the anchor.
6. When the anchor will begin to crawl on a roller, stop windlass electric motor in order to see that the anchor is not swinging and have occupied correct position. CHECK, THAT THE ANCHOR OCCUPIED CORRECT POSITION (Fig. D10).
7. Continue to stow the anchor, until it will be fixed on a stemhead roller.
8. Switch off windlass circuit breaker and then main battery disconnecter.
9. Hook safety pin to chain. Close the bow anchor hatch.

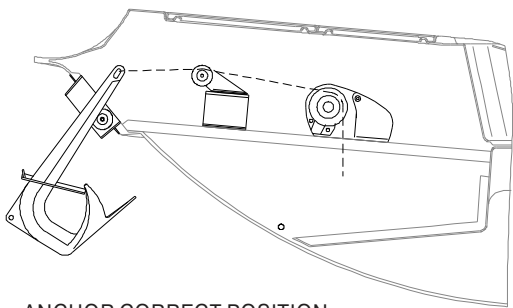

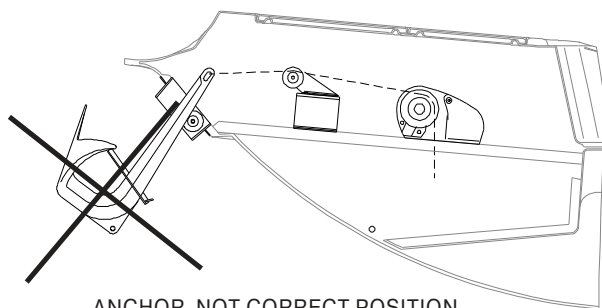

ANCHOR CORRECT POSITION.
CONTINUE TO STOW THE ANCHOR.



ANCHOR NOT CORRECT POSITION.
RESTART TO STOW THE ANCHOR.

D10

 WARNING	<p>CHECK, THAT THE ANCHOR HAVE OCCUPIED CORRECT POSITION AND ONLY AFTER THAT CONTINUE TO STOW THE ANCHOR.</p>
	<p>Safety pin must always been hooked to the chain when the windlass is not in use.</p>
	<p>Do not use the windlass for different purposes it was designed for.</p>
 WARNING	<p>Always turn off the windlass circuit breaker when the windlass is not in use to prevent any accidental engagement.</p>
	<p>Always keep hands and feet off an operating windlass. If the chain gets blocked, turn the windlass off and try to free the chain extremely carefully.</p>
 ATTENTION	<p>Check that the chain was not twisted in the area between the anchor and the windlass. Untwist it, if necessary.</p>
	<p>Periodically clean out the drain opening (7)(Fig.D9) from dirt.</p>

TOWING.

There are two U-bolts in the bow ((1) Fig.D10.1) of your boat for towing. Use both U-bolts at the same time to tow your boat. In towing rope (2) should be a means (3) to quickly disconnect your boat from the tugboat.

 WARNING	U-bolts for towing is designed for a maximum horizontal load of 19.3kN. The breaking strength of rope shall in general not exceed 80 % of the breaking strength of the respective strong point.
---	---

 WARNING	Always check the U-bolts and their attachment points to the boat hull for damage.
---	---

 WARNING	Always have a towing rope on board
---	------------------------------------

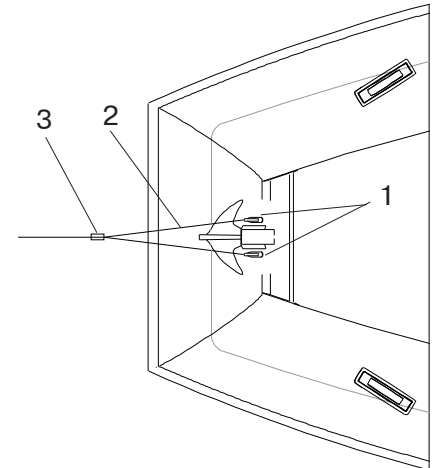
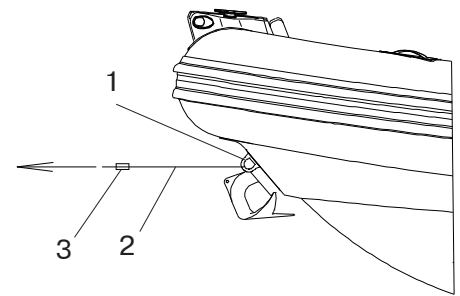

D10.1

MOORING.

For mooring on the boat are installed (Fig D10.2):

1 - two bow cleats, 2 - two U-bolts, 3 - two stern cleats.



Use bow cleats (1) only for mooring in calm water for a short time. If you are leaving the boat and there is a possibility of rough water or strong wind, use only bow U-bolts (2) to bow mooring.

Always use the rear cleats for mooring.

Do not use other parts or elements of the boat for mooring.

Make sure that the mooring rope does not damage the buoyancy tube or other elements of the boat.

Rope for mooring must be appropriate strength, diameter and length.

 WARNING	<p>U-bolts for mooring is designed for a maximum horizontal load of 19.3kN. Stern cleat for mooring is designed for a maximum horizontal load of 15.8kN. The breaking strength of rope shall in general not exceed 80 % of the breaking strength of the respective strong point.</p>	 DANGER	<p>Be careful when mooring. Suddenly tensioned mooring ropes may cause injury.</p>
---	--	--	--

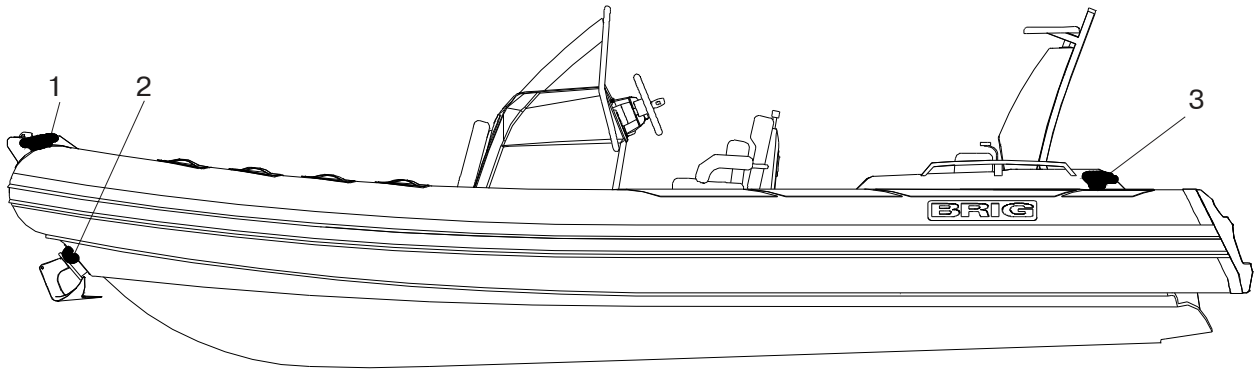

D10.2

HOW TO INSTALL SUNDECK.

In order to install the sundeck (Fig. D11), perform the next operations:

- open front seat (1) of the steering console;
- insert the sundeck floor boards (2) into the special hollows in the bow locker and front part of the steering console base;
- close front seat (1) of the steering console;
- set the sundeck cushions (3) on the press-buttons.

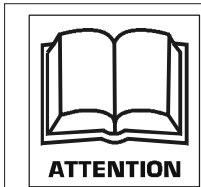
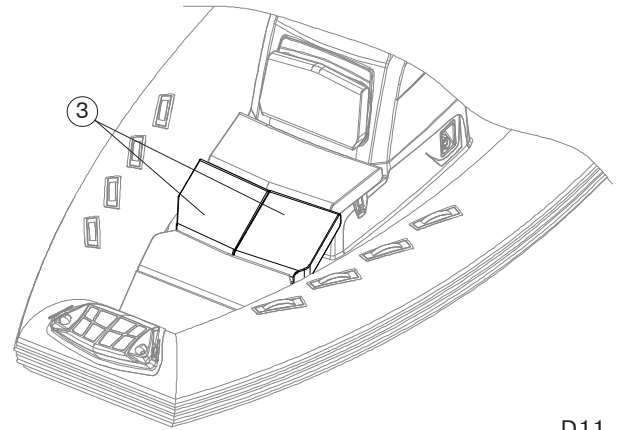
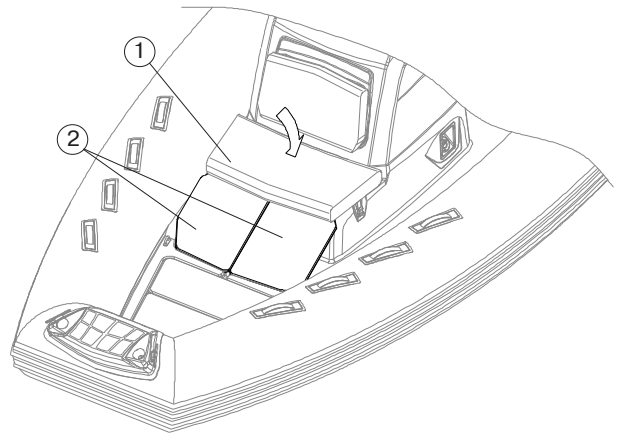
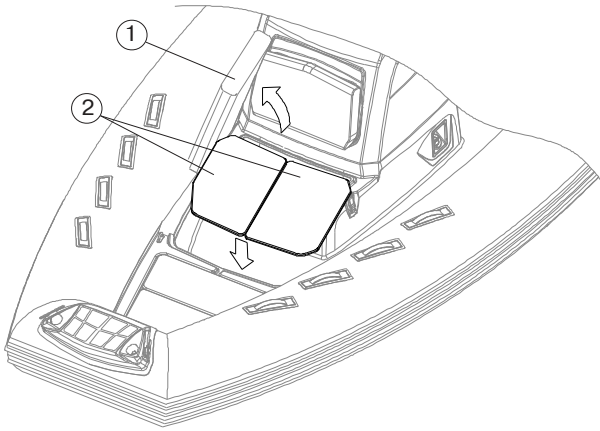



Always check fixing the sundeck cushions.

D11

REBOARDING MEANS.

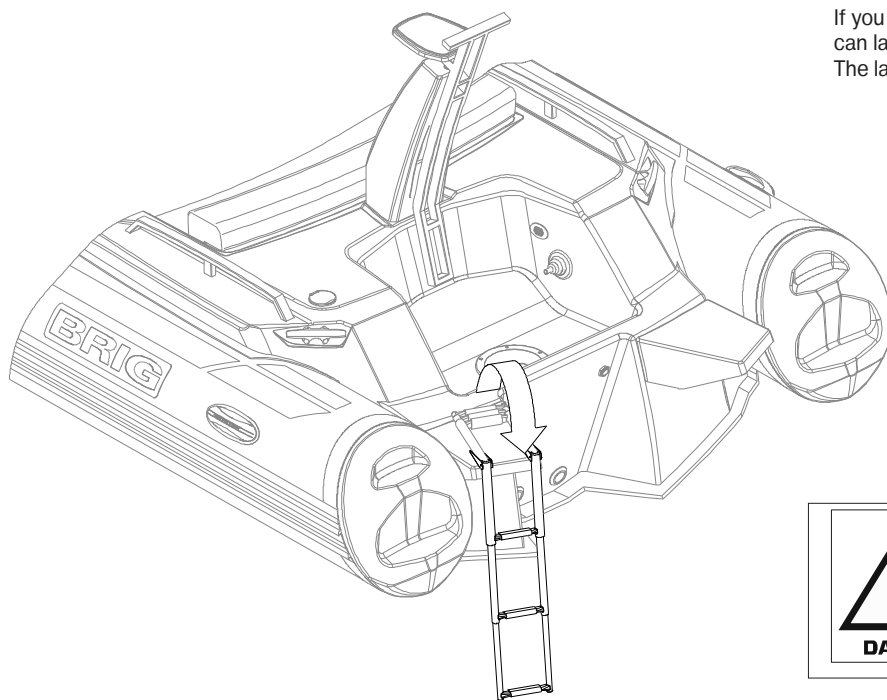
Reboarding ladder mounted on the stern of the boat on the starboard side.
If you are in the water, and the ladder is folded, you can lay out it and return onboard.
The ladder can be fixed with Velcro. Just unclip it.



 <p>DANGER</p>	<p>Be careful - the rotating propeller on the engine</p>
---	--

HOW TO INSTALL STORAGE BATTERY.

In order to install the storage battery, perform the next operations:

- open stern locker cover;
- install the storage battery in the battery container;
- connect the battery terminals with engine battery cord and battery disconnecter;
- check efficiency of the electric equipment.



BATTERY: the battery may cause sparks or explosions. It must be stored in an appropriate container, easily reached and well aired, **AWAY FROM FUEL OR INFLAMMABLE PRODUCTS**. Periodically check that the clips are tight and protect them with appropriate insulation in order to prevent sparks or the spread of current.



Do not modify electrics of the boat.

Any modification, repair and planned maintenance may be made by authorized representative specialists only.

Do not touch the electrical equipment with wet hands.



When leaving the boat, remember to disconnect the batteries.

Before installation your storage battery read the **BATTERY MANUAL** carefully and ensure that you have understood all the described procedures.

WIRING DIAGRAM.

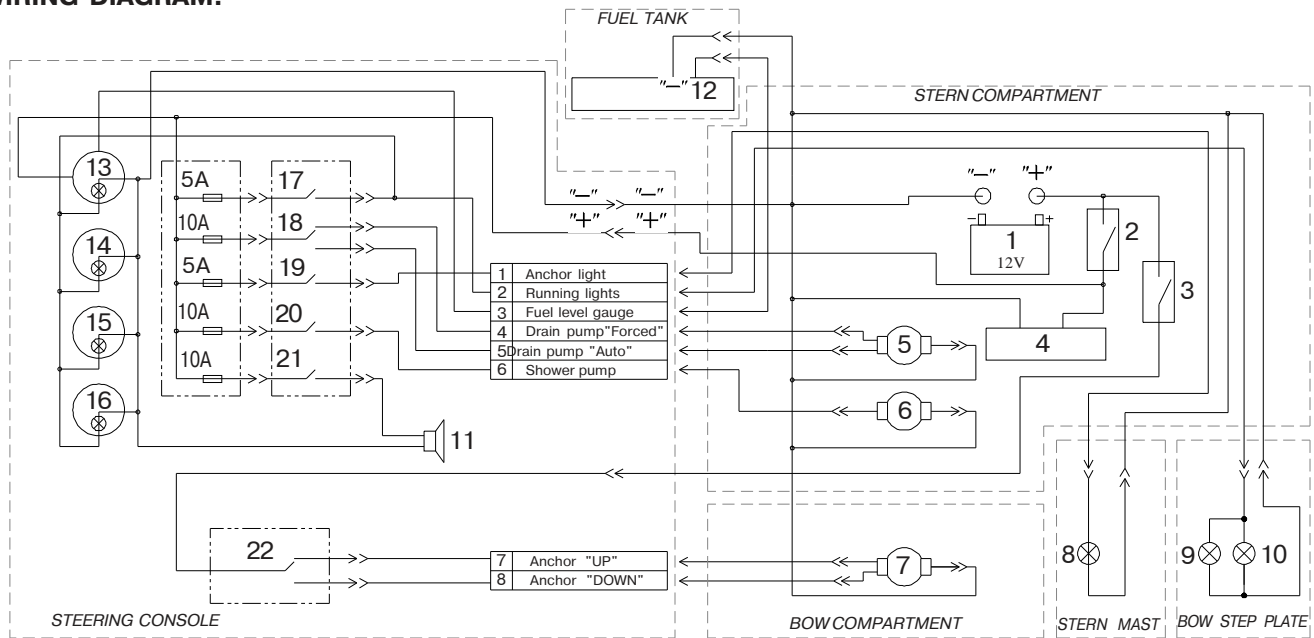

D12

DESCRIPTION:

- | | | |
|--|-------------------------------|---|
| 1 — Battery (provided on the market). | 9 — Port light (red). | 17 — Switch — meter lamp and running lights switch. |
| 2 — Battery disconnecter. | 10 — Starboard light (green). | 18 — Switch — automatic bilge pump "FORCED" / "AUTO". |
| 3 — Anchor windlass relay breaker. | 11 — Electric horn. | 19 — Switch — anchor light (white). |
| 4 — Outboard motor (provided on the market). | 12 — Fuel level gauge. | 20 — Switch — shower pump. |
| 5 — Automatic bilge pump. | 13 — Fuel level clock | 21 — Switch — electric horn. |
| 6 — Shower pump. | 14 — Tachometer. | 22 — Switch — anchor "UP" / "DOWN". |
| 7 — Anchor windlass. | 15 — Compass | |
| 8 — Anchor light (white). | 16 — Speedometer. | |

INFLATION/DEFLATION BOAT TUBE.

The tube of the boat has some independent air-tight chambers. Before inflation of compartment it's necessary to set all valves in operating condition. In order to switch valve to operating condition, just press spindle 6 (look before Fig. D3) with your finger and turn it clockwise until it is fixed. If it isn't possible the valve is in operating condition already.

Fill the tube compartments with air using the pump from the complete set. First fill two rear compartments, then middle compartments. Thereat, do not bring the pressure up to its operating value (the tube will be completely straightened). Then fill the bow compartment with air up to the rated pressure. **The rated pressure value is 0.2 bar (2.9 psi).** On completion of filling close the valves with caps.

In order to discharge air from the compartments, open the valves (just press spindle with your finger and turn it anticlockwise till it is fixed).



Do not use compressors and/or other types of inflating equipments not approved by the boat builder.

Check tube pressure before every navigation.

The rated pressure value is 0.2 bar (2.9 psi).

If the tube pressure more than nominal, deflate the compartments slightly. Boat exploitation with board pressure more than nominal decreases boat service life.



Board air chambers are hermetical if they keep own form during 8 hours. In this case:

- primary pressure has to be nominal;
- input valves openings have to be tightly closed by caps.

BOAT TRAILERING.

Installed on a trailer (or on keel-blocks for storage) the boat should be laying on all surface of the Main loading area (keel line) (see Fig. T1).

It is possible to install the boat on several reference points. Thereby the point of support (1) must be an obligatory, and the point of support (2), (3), (4) must be an additional.

Lateral roller supports can be used only with a view of prevention from tipping.

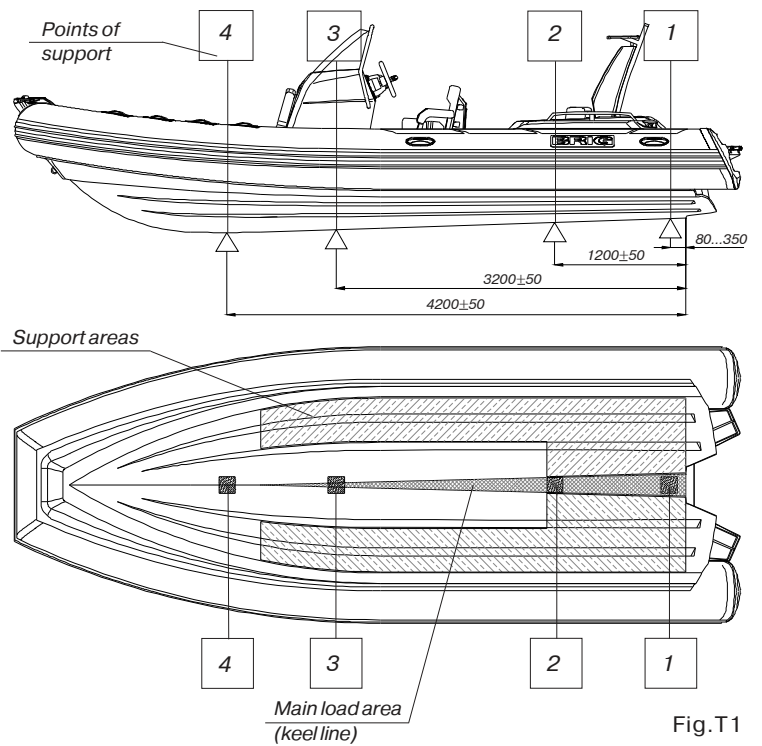



Fig.T1

 <p>ATTENTION</p>	<p>Maximum transportable mass – 1650 kg</p>
---	--

 <p>ATTENTION</p>	<p>In order to avoid the hull damage install the boat on the stated areas only.</p>
---	---

MAINTENANCE.

- Main conditions of long service life is right and careful servicing. Avoid excessive increasing of pressure in the board, especially from heating by the sun rays.
 - After exploitation take off sand and dirt from boat surface, and carefully dry it.
 - Avoid the water getting into the chambers. If a fuel or an oil gets to the boat surface it is necessary to wash the soiling place by soap water as soon as possible and dry.
 - Pay attention to the condition of bottom surfaces. If it's cover is destroyed it is necessary to dry this element and restore the defend cover.
 - After season prepare the boat to winter keeping. Clean boat surface from sand and dirt and make the necessary repairs, if damages take place. If it is possible, keep the boat in the open and slightly pumped state in air temperature 0-25°C. The boat must be protected from the sun rays.
 - Insignificant boat repairing (eliminating the board punctures or cuts) you may carry out by yourself. In this case use the coated fabric and glue set for repair from the complete set.
- Independent performance of any complex repair associated with considerable damages to the board, partitions and seams is not recommended. In such cases, apply to your dealer.

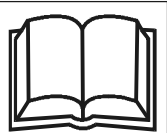

ATTENTION

Storage of the boat with temperature variations from -30°C to +45°C may be allowed for not longer than 1 month.





In case the boat has being stored or transported at a temperature bellow 0°C, it must be held at a temperature above +15°C for at least 1 hour before be unpacked and unfolded.





For repair boat tube use the coated fabric and glue set from the complete set.

OPERATING REGULATIONS.

Dear user,

We thank you for your purchase and do hope that you will have a great fun of it. However, to make your joy and pleasure complete, we would request you to read carefully and observe the directions and recommendations specified below.

 DANGER	IT IS STRICTLY FORBIDDEN to handle the boat in the state of intoxication and without individual rescue means being used (life-saving belts, jackets, etc.)
	IT IS FORBIDDEN to use an outboard engine of power exceeding the maximum allowable value
 WARNING	IT IS FORBIDDEN to bring the tube pressure up to the value exceeding the rated one (0.2 bar(2.9psi))
	IT IS STRICTLY FORBIDDEN to drag the boat across a rough surface.
	For each particular water area the local shipping regulations are in force. You may apply for information to the appropriate water transport and shipping directorate, as well as to the water police.
 WARNING	Use the boat equipment and accessories only on their direct purpose to ensure reliable service.
	Even when sailing with an outboard engine you should always have the oars available with you so that you were able to reach the shore without outside assistance in case of any damage to the boat.
 WARNING	On your request any outboard engine seller may provide your engine with the emergency stop switch. During navigation the switch should be connected to the wrist of your hand by means of a cord. In case you fall overboard, even if being a steersman, the switch will cut out the engine and the propeller. This arrangement will enable you to avoid any traumas and to reach the boat.
	Take all possible precautions against penetration of fuel, oil or electrolyte from the storage battery into the inflatable boat. If it does happen wash thoroughly the fouled spots with water.

	<p>You should be always sure that the number of people on board never exceeds that specified in the owner's manual or on the builder's plate provided on the transom.</p> <p>The boat will retain an adequate floatability and will not keel over only provided that the load is arranged reasonably. Therefore, do not accommodate all passengers on the same side of the boat.</p>
	<p>All passengers should be accommodated inside the boat. The occupied seats should not be left throughout the entire sailing time.</p>
	<p>All passengers should put on life-saving jackets</p> <p>CHILDREN and non-swimmers MUST BE A FLOATATION DEVICE AT ALL TIMES.</p> <p>Always check that floatation devices for children are of the right size and that they are operational.</p>
	<p>The boat must be equipped with liferaft(s) to be stowed for the crew limit. If the liferaft is a rigid canister type, it shall be mounted in the cockpit, ready for use. If the liferaft is contained in a soft bag then it may be stowed in a compartment but shall be readily available for use.</p> <p>Liferaft not supplied by the manufacturer and must be installed by owner.</p>



Arrange the cargo to be carried uniformly inside the boat, all items being reliable secured on the bottom of the boat.

When sailing with an outboard engine the steersman should shift his body forward in the course of acceleration to prevent the boat forebody from raising under the force of upthrust waves.



Despite the strong shell of the boat we are recommended to handle sharp and pricking objects being on board with care. For example, it concerns a knife blade, fish-hook point, etc.



Approach rocky shores, shoals, moles, etc. carefully to avoid damages to the boat. It is strictly prohibited to drag the boat across rough surfaces (shingle, rocks, concrete, etc.).

In case of prolonged navigation with the use of an outboard engine, regularly check to ensure that the engine is reliably attached to the boat. If the engine was attached carelessly the attachment may work loose under the action of vibration.



Besides, check air chambers pressure at regular intervals, since the pressure may vary under the effects of outside air temperature and atmospheric pressure variations.

Never forget to monitor regularly the quantity of fuel in the fuel tank. Keep always in mind that the quantity of fuel should be sufficient for you to sail to your final destination.

TOWING.

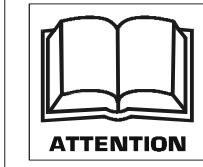

At towing, the towing rope length should be at least 3 lengths of the boat.

The steersman of the towed boat should be assisted by another crew member to monitor the process of towing. In this case, certain communication gestures should be agreed upon beforehand.



The rope being secured to both boats in a manner ensuring its immediately, single-motion release.

DAMAGE OF ONE OF THE AIR CHAMBERS.

The inflatable boat is designed to provide an adequate stability in case of the complete damage of one of the air chambers (tube compartments) at the expense of the remaining air chambers and the hull. Thanks to it, you will be able to reach safely to the nearest shore. Reduce the speed and shift your body to the undamaged part of the boat. Watch changes in stability. After this immediately head to the nearest shore. To prevent penetration of water into the boat, pull the shell of the damaged air chambers upwards.

ANCHOR AND MOORING FAST FASTENING.



Fix the towing rope in the bow of the boat to the front towing ring.
Fix the anchor or mooring ropes in the bow of the boat to the bow cleat only.
Fix the back anchor or mooring ropes to the back cleats only.

DANGER OF CURRENTS AND WIND.



Before navigation of the boat make detail inquiries about local conditions and regulations! Currents, wind, shoals, rising and falling tides, as well as weather variations may imply serious danger!

IN EMERGENCY STAY IN THE BOAT.

In any unexpected situation (engine failure, boat damage, etc.) do not ever leave the boat provided it is still afloat. Even if you believe that the shore is just nearby stay in the boat, since you will be looked for in this particular place and, most probably, will be found. Should the boat become partially flooded throw heavy objects (batteries, fuel tank, engine) overboard to ensure additional floatability.

HANDLING UNDER POWER.



Manoeuvrability above **40knots (74 km/h)** is limited. Sudden turn may cause loss of control. Reduce speed before making sharp in either direction.



Maximum propulsion power rating fo the boat **166 kW (225 HP)**



Do not operate your boat with an engine of rated power larger than that posted on the builder's plate in the boat.



Do not operate this craft at negative propulsion unit trim settings (bow down) at high speed. Craft may lean over on side. Instability in turns may result. Use negative trim to accelerate to planing speed from displacement speed and at lower planing speeds in choppy water (applicable to craft equipped with propulsion unit power trim).

Do not operate at maximum speed while in congested high traffic waterways or in weather and sea conditions of reduced visibility high winds or large waves. Reduce speed and wake as a courtesy and as a safety consideration to yourself and others. Observe and obey speed limit and no wake zones.



Observe right-of-way as defined by Rules of the Road and required by COLREG.

Always be certain to have sufficient distance to stop or manoeuvre if required to avoid collisions.

● **WARNING SIGNS AND LABELS.**

In accordance with ABYC standards, warning signs and labels are installed on your boat (if applicable). Do not remove warning signs and labels. Always check their suitability. If the warning signs are damaged and you cannot read the text or symbols, you must order new ones from your dealer. Check with your dealer for the correct warning signs and labels mounting location.

BOAT CAPACITY LABEL.

Place of installation: on the hull near the stern seat



WARNING. MAXIMUM ENGINE WEIGHT.

Place of installation: on the hull of the boat near the outboard engine.



WARNING. LEAKING FUEL

Place of installation: on the hull near of the fuel filler.

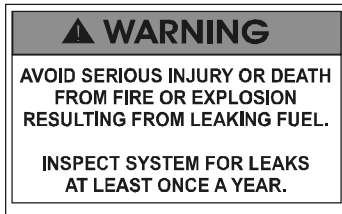

WARNING. ROTATING PROPELLER

Place of installation: from the outside of the boat transom.

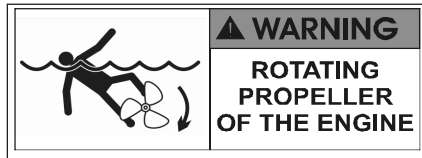



WARNING. FAILURE TO FOLLOW THESE WARNINGS COULD SEVERE INJURY OR DEATH

Place of installation: on the steering console.

▲ WARNING

Failure to follow these warnings could cause SEVERE INJURY or DEATH

- **CARBON MONOXIDE (CO) CAN CAUSE BRAIN DAMAGE OR DEATH.**
 - Engine and generator exhaust odorless and colorless carbon monoxide gas.
 - Signs of carbon monoxide poisoning include nausea, headache, dizziness, drowsiness, and lack of consciousness
 - **MOVE TO FRESH AIR** if anyone shows signs of carbon monoxide poisoning.
- **CHECK WEATHER FORECAST BEFORE DEPARTING DOCK** and heed all weather advisories
- **WEAR SAFETY LANYARD** at all time while operating boat to prevent unmanned operation.
- **NEVER OPERATE WHILE UNDER THE INFLUENCE** of drugs or alcohol.
- **DO NOT OVERLOAD THE BOAT. ENSURE THAT WEIGHT IS PROPERLY AND EVENLY DISTRIBUTED** fore and aft and on both side of the boat to avoid poor handling, sudden loss of control, swamping and/or capsizing.
- **PASSENGERS SHOULD WEAR U.S. COAST GUARD APPROVED LIFE JACKETS.**
- **MAKE SURE THAT ALL PASSENGERS ARE PROPERLY SEATED WHILE UNDERWAY.** To avoid passengers falling overboard or being ejected from the boat, do not allow passengers to sit on seat backs, gunwales or outermost deck edges while boat is moving.
- **REDUCE SPEED BEFORE ATTEMPTING SUDDEN OR SHARP TURNS, AND MAINTAIN SAFE SPEEDS** for water conditions and environment at all times. Maneuverability at high speeds is limited, and sudden turns may cause loss of boat control.
- **KEEP PROPER LOOKOUT AND SAFE DISTANCE** for the conditions at all time to avoid collisions.
- **OBEY APPLICABLE NAVIGATION RULES AND BOATING LAWS.**
- **USE CAUTION AND PROPER LIGHTING** during night time and boating in adverse weather.
- **READ THE OWNER'S MANUAL AND COMPLETE THE BOAT'S PRE-OPERATION CHECKLIST** prior to boat operation.

The inflatable boat was delivered with the following equipment installed:

Fuel tank with fuel hoses	Stamp and signature	Comments:
Electric system	Stamp and signature	Comments:
Drain system.	Stamp and signature	Comments:
Bilge pump	Stamp and signature	Comments:
Shower kit	Stamp and signature	Comments:

Steering system	Stamp and signature	Comments:
Anchor system	Stamp and signature	Comments:
Engine power system	Stamp and signature	Comments:
Engine installation, test and completion of plants and fittings done by.	Stamp and signature	Comments:
		Comments:



MODEL	<input type="text" value="Eagle 6.7"/>
SERIAL No.	UA-QRK <input type="text"/>
Date of manufacture	<input type="text"/>
Quality inspection stamp	